

***DT* SWISS**

RATCHET EXP HUBS
TECHNICAL MANUAL

V2022.01

1. GENERAL	3
1.1 Validity.....	3
1.2 Safety	3
1.3 Target group.....	3
1.4 Layout.....	3
1.5 DT Swiss manual concept	3
1.6 How to use the manual	4
1.7 General Maintenance Information.....	4
1.8 Environmental protection.....	4
1.9 Exclusion of liability.....	4
1.10 Warranty.....	4
2. MAINTENANCE OF THE REAR WHEEL HUB WITH RATCHET EXP® SYSTEM.....	5
2.1 Overview.....	5
2.2 Required tools.....	6
2.3 Required wearing parts and materials.....	6
2.4 Removing end caps, freewheel body and freewheel system	8
2.5 Dismounting the ball bearing on the non drive side	9
2.6 Dismounting the threaded ratchet	10
2.7 Dismounting the bearing from the threaded ratchet.....	11
2.8 Checking the sealing.....	12
2.9 Cleaning and checking all parts	12
2.10 Pressing the ball bearing into the threaded ratchet.....	13
2.11 Screwing the threaded ratchet with the bearing into the hub shell.....	14
2.12 Mounting the ball bearing at the non drive side	16
2.13 Mounting the hub seal.....	17
2.14 Mounting the freewheel system.....	18
2.15 Putting on the freewheel body and the end caps	20
2.16 Check the functionality.....	20
3. TROUBLE SHOOTING.....	22

1. GENERAL

1.1 VALIDITY

This manual describes the component specified on the front page and the footer. This manual is valid for the design of the product as of 17.10.22. Deviations are possible and all items are subject to technical changes.

1.2 SAFETY

The safety instructions are classified as follows:



DANGER

...indicates a hazardous situation that, if not avoided, will result in death or serious injury.



CAUTION

... indicates a hazard with a medium level of risk which, if not avoided, may result in minor or moderate injury.



NOTE

... indicates a potentially hazardous situation that may result in damage to property.

1.3 TARGET GROUP

This manual is intended for the user of the component and dealers. This manual offers the experienced user the possibility to carry out minor service work himself. If you have any doubts about your own abilities, you should definitely contact an expert or a DT Swiss Service Center. Any warranty claims will lapse if work is not carried out properly.

1.4 LAYOUT

The cover page and the footing provide information about the type of product and manual as well as the version of the manual. The DT Swiss contact details can be found on the back. A list of all DT Swiss service centers can be found at www.dtswiss.com.

This manual is intended for being printed as an A5 booklet. Only print this manual if electronic usage is not possible.

1.5 DT SWISS MANUAL CONCEPT

The DT Swiss manuals are split into the following types of manuals:

- User Manual: Information for the end user on how to install and use the component.
- Technical Manual: Detailed information for the end user and the dealer on how to maintain the component, spare parts and technical data.

1.6 HOW TO USE THE MANUAL

The steps described in this manual must be carried out in the order they are shown. If steps are ignored or executed in a wrong order, the function of the component cannot be guaranteed.

1.7 GENERAL MAINTENANCE INFORMATION

Unless otherwise specified, moving parts, threads, O-rings and sealings must be greased before assembly.

CLEANING

For an optimal result of the maintenance works, every component that will be disassembled must be cleaned. Only use cleaners and degreasers which do not damage the components. Especially the cleaning of O-rings and sealings requires mild cleaners. Observe the instructions for use of the respective cleaner.

DT Swiss recommends the following cleaners:

- Motorex Rex
- Motorex Swissclean
- Motorex OPAL 2400, 3000 OPAL, OPAL 5000

Use soap water or similar mild cleaners for external cleaning.

TOOLS

To ensure a damage-free mounting and dismounting of the components, only use the tools which are mentioned in this manual. Special tools are indicated at the beginning of a chapter in the table "Required material".

The use of different tools is at the discretion of the user. If components are damaged by the usage of differing tools, the user is liable.

DT Swiss special tools are precision tools. Damage-free mounting and dismounting of the components can only be ensured if the tools are working properly and if the condition of the tools are perfect. Always keep the tools in their original packaging or adequate devices to prevent damage.

1.8 ENVIRONMENTAL PROTECTION

The statutory regulations shall apply. Whenever possible, avoid creating waste. Waste, especially carbon, lubricants, cleaners and any other fluids must be disposed in an environmentally compatible manner.

Only print this manual if electronic usage is not possible.

1.9 EXCLUSION OF LIABILITY

The activities listed in this manual may only be carried out by persons with sufficient specialist knowledge. The user is liable for any damage or consequential damage caused by wrongly maintained or installed components. If you have doubts, please contact an expert or your region's DT Swiss pro level service center.

1.10 WARRANTY

Warranty conditions, see www.dtswiss.com

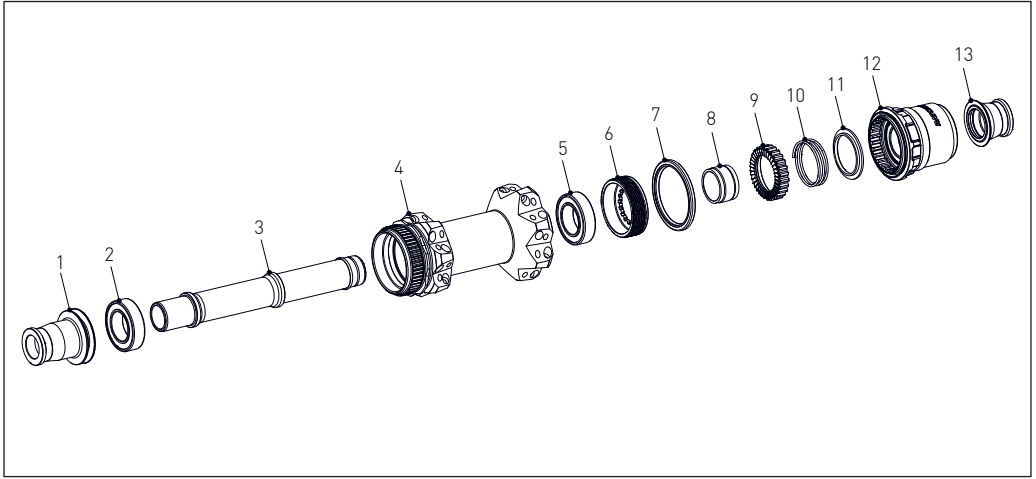

2. MAINTENANCE OF THE REAR WHEEL HUB WITH RATCHET EXP® SYSTEM

2.1 OVERVIEW



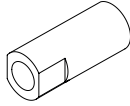
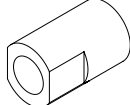
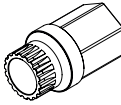
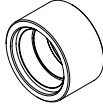

1	end cap non drive side	8	spacer
2	ball bearing non drive side	9	loose ratchet
3	axle	10	spring
4	hub shell	11	washer
5	ball bearing drive side	12	freewheel body
6	threaded ratchet	13	end cap drive side
7	hub seal		







2.2 REQUIRED TOOLS

Tools	Specification	Quantity	Article number
tool kit*, consisting of:		1	HWTXXX00N2544S
installation cylinder Ø15 x 24 x 60 mm (only required for ball bearings on the non drive side with 180 hubs)		1	HXTXXX00N5025S
installation cylinder Ø15 x 26 x 40 mm		1	HXTXXX00N5314S
mounting / dismounting tool for the threaded ratchet		1	HXTXXX00N8387S
mounting / dismounting tool ball bearing drive side		1	HXTXXX00N6106S
installation tool for hub seal		1	HXTXXX00N1000S

* The tool kit can be purchased as a complete set or the included tools can be purchased separately.

2.3 REQUIRED WEARING PARTS AND MATERIALS

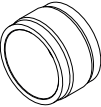
Wearing parts / Materials	Specification	Quantity	Article number
DT Swiss universal grease		20 g	HXTXXX00NMG20S
DT Swiss special grease		20 g	HXT10032508S

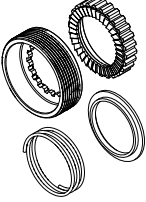
Wearing parts / Materials	Specification	Quantity	Article number
ball bearing for 180 hubs: <ul style="list-style-type: none"> • Drive side 1526 Ø15 x 26 x 7 mm 		1	HSBXXX00N3741S
<ul style="list-style-type: none"> • Non-drive side 6802 Ø15 x 24 x 5 mm 		1	HSBXXX00N2464S
ball bearing for 240 hubs: Drive side / non-drive side 1526 Ø15 x 26 x 7 mm		2	HSBXXX00N3741S
hub seal		1	HSOXXX00N1031S
spacer			HRDXXX00N8242S
Service Kit 36 teeth consisting of <ul style="list-style-type: none"> • loose ratchet 36T • threaded ratchet 36T • spring • washer • DT Swiss special grease 		1	HWYXXX00N0042S
Service kit 54 teeth consisting of: <ul style="list-style-type: none"> • loose ratchet 54T • threaded ratchet 54T • spring • washer • DT Swiss special grease 		1	HWYXXX00N9376S

2.4 REMOVING END CAPS, FREEWHEEL BODY AND FREEWHEEL SYSTEM

1. Pull off both end caps by hand.

If the end caps cannot be pulled off by hand, clamp the end caps carefully into a vise with ground clamping jaws and pull the hub / wheel upwards.



2. Pull the freewheel body off the hub.



3. Pull the spacer off the axle.



4. Remove the spring, the ratchet and the washer from the freewheel body.



2.5 DISMOUNTING THE BALL BEARING ON THE NON DRIVE SIDE

1. Tap out the ball bearing on the non drive side with a plastic hammer with slight hammer strokes onto the axle.



2. Remove the ball bearing from the axle.



2.6 DISMOUNTING THE THREADED RATCHET

Due to the torque acting on the ring nut during pedaling, the ring tightens while riding. Therefore, loosening the ring nut requires a high force. The ring nut can only be loosened, when the wheel is complete as the lever is much larger.

1. Clamp the mounting / dismantling tool for the threaded ratchet into the vice.
2. Fit the hub or wheel onto the tool in such a way that the teeth of the tool engage in the teeth of the threaded ratchet.
3. Insert the axle with the long side first into the hub and through the threaded ratchet.
→ If the axle is inserted through the ratchet with the short side first, the tool is not sufficiently guided. The axle, the ratchet or the tool can be damaged.

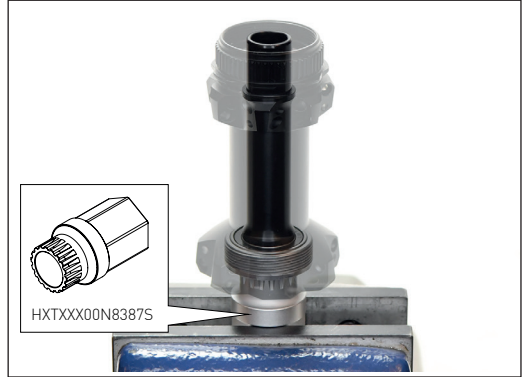

4. Push the installation cylinder onto the non drive side of the hub.
5. Loosen and screw off the ratchet by turning the hub counterclockwise.
→ While unscrewing the threaded ratchet, some pressure should be applied to the hub from above so that the tool engages securely in the ratchet at all times.



6. Remove the hub from the tool.
7. Remove the ratchet with the bearing.



2.7 DISMOUNTING THE BEARING FROM THE THREADED RATCHET

1. Put the threaded ratchet with the bearing into the mounting / dismantling tool.
 - The tothing of the threaded ratchet must face upwards.
 - Put the ratchet on the side of the tool with the fitting diameter. The ratchet may only move minimally in tool.



2. Slide the axle with its short end through the bearing.



3. Use a plastic hammer to knock the ball bearing out of the ratchet with light hammer strokes.



4. Remove the ratchet and the bearing from the tool.



2.8 CHECKING THE SEALING

The sealing must only be dismantled and changed when it is damaged.

1. Check the sealing for damages.
2. If there is clearly visible damage, replace the sealing:

To replace the sealing, there is a notch in the hub shell.

3. Using a slotted screwdriver with a blade width of 2.5 mm, slide under the seal into the notch in the hub shell.
4. Turn the screwdriver 90° around its longitudinal axis and push the seal out of its seat.



2.9 CLEANING AND CHECKING ALL PARTS

1. Clean all parts of the hub, threaded ratchet, sleeve, spring and end caps. The existing grease must be completely removed from the hub body and from the threaded ratchet.
2. Check the ratchets for wear.

The wear of the ratchets usually starts at the outer circumference and shows itself by strongly flattened edges with uneven wear.

In case of heavy wear, the ratchets must be changed immediately.



3. Check the internal teeth of the freewheel body for wear.

If the black surface of the gearing is heavily worn (no longer black but silver), if there are burrs or if material has been removed, the freewheel body must be replaced.

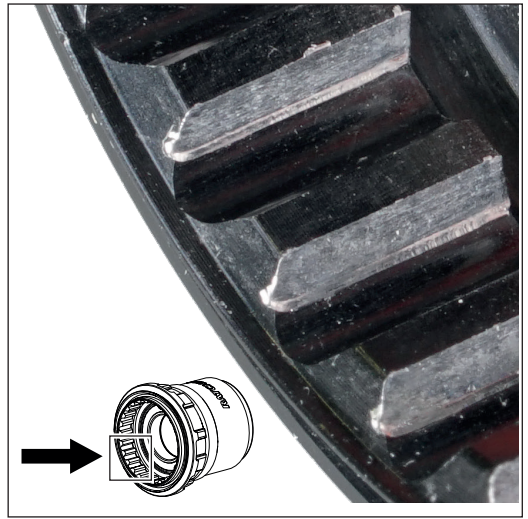

2.10 PRESSING THE BALL BEARING INTO THE THREADED RATCHET

1. Slightly grease the contact surface of the bearing and the threaded ratchet.
2. Put the threaded ratchet with the tooting facing downwards onto the mounting / dismounting tool.
 - Put the ratchet on the side of the tool with the fitting diameter. The ratchet may only move minimally in the tool.
3. Put a new ball bearing with the colored side facing downwards onto the ratchet.



4. Carefully press the bearing into the ratchet with light hammer strokes on the outer ring of the ball bearing until the bearing protrudes 1 to 2 mm beyond the ratchet.
 - The ball bearing must not be pressed further into the ratchet.

2.11 SCREWING THE THREADED RATCHET WITH THE BEARING INTO THE HUB SHELL

1. Slightly grease the threaded ratchet and the thread of the hub shell with universal grease.
2. Put the installation cylinder into the vise.
3. Insert the axle into the installation cylinder with the short side first.



4. Push the hub shell onto the installation cylinder with the drive side facing upwards.



5. Slide the threaded ratchet with the ball bearing onto the axle.
→ The tothing of the threaded ratchet must face upwards.



6. Push the mounting tool into the toothing of the ratchet and screw the ratchet into the hub shell by a few turns with light pressure.

- Before the ratchet engages in the thread of the hub shell, it must be pushed over the sealing (if the sealing is installed) with a little pressure.
- While screwing in, make sure that the ratchet is screwed in straight and does not cant!



- It must be possible to screw in the ratchet without effort until a high resistance is created. Now the ball bearing is in contact with the hub shell and the ratchet must be brought into the end position with greater force. Continue with next step.

7. Remove the mounting tool, remove the hub from the installation cylinder and unclamp the installation cylinder from the vice.
8. Clamp the mounting / dismantling tool for the threaded ratchet into the vice.
9. Slide the axle with its long end through the ball bearing.



If the axle is inserted through the ratchet with the short side first, the tool is not sufficiently guided. The axle, the ratchet or the tool can be damaged.



10. Put the hub / the wheel with the mounted ratchet onto the mounting tool.

11. Push the installation cylinder onto the non drive side of the hub.

- By using the axle and the installation cylinder, the hub shell is guided when the ratchet is screwed on. The ratchet cannot cant.

12. Tighten the threaded ratchet as tight as possible by turning the hub clockwise by hand.

- During tightening of the threaded ratchet, some pressure should be applied to the hub from above so that the tool engages securely in the ratchet at all times.



13. Remove the hub from the mounting / dismantling tool and put the tool out of the vice.

2.12 MOUNTING THE BALL BEARING AT THE NON DRIVE SIDE

1. Make sure that the axle is in the hub with the long side first.
2. Grease the bearing seat and the axle with universal grease.



3. Push a new bearing on the axle with the colored side facing outwards.



4. Clamp the mounting / dismantling tool for the threaded ratchet into the vice.
5. Put the hub on the tool in the vice.
6. Put the installation cylinder onto the bearing.
7. Tap in the ball bearing carefully with slight hammer strokes.



8. Check the ball bearings.
 - It must be possible to turn the hub with slight resistance.
 - The hub must not have axial play.
9. Tap the ball bearing on the non drive side in or out and repeat previous steps until the hub is turning smoothly.



2.13 MOUNTING THE HUB SEAL

1. Put the sealing onto the mounting tool.



2. Make sure that the axle is in the hub with the short side first.
3. Put the mounting tool with the sealing onto the axle.
4. Push on the installation cylinder and drive in the sealing with slight hammer strokes.

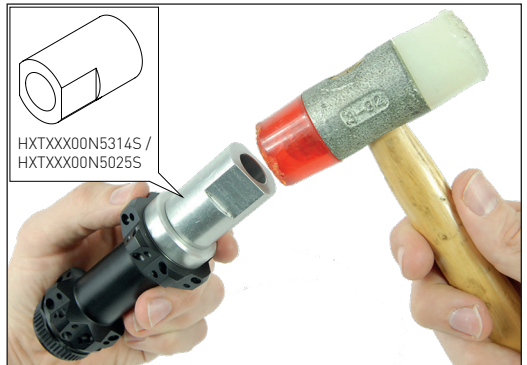

2.14 MOUNTING THE FREEWHEEL SYSTEM



DANGER

RISK OF INJURY DUE TO LIMITED FREEWHEEL FUNCTION DUE TO INCORRECT LUBRICATION!

If too much grease is applied on the ratchets, the actuation of the ratchets may not work. The ratchets may slip during pedaling.

- Only apply a thin, even layer of grease.
- Only use the red DT Swiss special grease.

1. Apply DT Swiss special grease evenly to the outer and the inner tooting of the ratchets using a fine brush.

→ For an optimal functionality of the freewheel system, a thin layer of grease is sufficient.



2. Put the spacer onto the axle.



- Put the spring onto the washer and put the ratchet onto the spring.



- Put the washer, spring, and ratchet into the freewheel body.



2.15 PUTTING ON THE FREEWHEEL BODY AND THE END CAPS

1. Put the freewheel body onto the hub.
2. Check if the freewheel body can be turned and if the ratchets are engaging.



3. Grease both bearings and the inner side of both end caps.
4. Put on the left and the right end cap.
→ The shorter end cap must be placed on the drive side.



2.16 CHECK THE FUNCTIONALITY

1. Turn the freewheel body in both directions.
→ The freewheel body can be turned counterclockwise easily.
The ratchets engage audibly and perceptibly.
→ The freewheel body cannot be turned clockwise.
2. Check the tightness of the end caps.
→ The end caps are firmly seated on the axle and are fully pushed on.



3. TROUBLE SHOOTING

Issue	Reason	Solution
Freewheel is blocked	Spacer was forgotten during assembly.	Check correct assembly, see "2.1 Overview", page 5.
	Spacer was compressed by overtightening the thru axle.	Measure the length of the spacer. If the spacer is shorter than 10.7 mm, it must be replaced.
Freewheel does not engage / slips	Loose ratchet is mounted upside down.	Check correct assembly, see "2.1 Overview", page 5.
	Too much or wrong grease on the ratchets.	Clean and grease ratchets, see "2.14 Mounting the freewheel system", page 18.
	Ratchets are worn.	Replace ratchets.
	Spring was forgotten during assembly.	Check correct assembly, see "2.1 Overview", page 5.
	Wear of the internal teeth of the freewheel body	Replace ratchets, replace freewheel body. Thoroughly clean the freewheel system.
Hub has axial play	Ball bearings were not mounted correctly.	Check correct assembly, see "2.1 Overview", page 5.
	Ball bearings are worn out.	Replace ball bearings.
Hub rotates stiffly	Ball bearings are worn out.	Replace ball bearings.
	Ball bearing non drive side too tight.	Check correct assembly, see "2.1 Overview", page 5.
	Mounting sequence of the ball bearings not observed.	
	Ball bearing pressed too far into the threaded ratchet before assembly.	
Hub makes noise	Ball bearings are worn out.	Replace ball bearings.
Notches from the cassette on the freewheel body.	The steel cassette works itself into the alloy web of the freewheel body.	Remove bad notches from the rotor using a file.
Freewheel body rotates with difficulty.	Ball bearings in the freewheel body are worn out.	Replace freewheel body.
Freewheel is too noisy / too quiet.	The perception of the freewheel sound is very subjective. While some riders prefer a loud freewheel sound, other riders want a quiet freewheel. In principle, the freewheeling sound can be influenced by the amount of grease between the ratchets. Less grease increases the freewheeling sound, but at the same time leads to higher wear.	

DT SWISS AG

Längfeldweg 101
CH - 2504 Biel/Bienne
service.ch@dtswiss.com

DT SWISS, INC.

2493 Industrial Blvd.
USA - Grand Junction, CO 81505
techusa@dtswiss.com

DT SWISS (FRANCE) S.A.S.

Parc d'Activites de la Sarrée
Route de Gourdon
F - 06620 Le Bar sur Loup
service.fr@dtswiss.com

DT SWISS ASIA LTD.

No.5, Jingke 5th Rd., Nantun District
Taichung City 408
Taiwan (R.O.C.)
service.tw@dtswiss.com

DT SWISS DEUTSCHLAND GmbH

Albert-Einstein-Strasse 3
59302 Oelde
Germany
service.de@dtswiss.com

DT SWISS POLSKA Sp. z o.o.

ul. Towarowa 36
PL-64-600 Oborniki
Poland
service.pl@dtswiss.com

Subject to technical alterations, errors and misprints excepted.

All rights reserved.

© by DT SWISS AG

www.dtswiss.com

HXD10000003111S